

Research Entitlements Standard

Common Element Taxonomy

Version 2.0

04th October 2006

Developed by the Entitlements Technical Committee (<http://www.researchentitlements.net>)

Status: Approved for release

DOCUMENT CONTROL

Version	Date	Author	Description
1.0	11/09/2006	Russell Ritchie	Approved First Release
1.1	18/09/06	Michael Gamber	Entity reference guide inserted
1.2	19/09/2006	Richard Inman	Amended spelling and small mistakes.
1.3	02/10/06	Michael Gamber	Updated after feedback of Steering Committee
2.0	04/10/06	Michael Gamber	Final version for release 2.0

This document was last revised or approved by the membership of the Entitlements This document is only valid on the day it was released.

This document was last revised or approved by the membership of the Entitlements Consortium on the above date. Check the current location listed below for possible later revisions of this document. This document is updated periodically on no particular schedule.

Document Location: <http://www.researchentitlements.net/>

The website has full contact details for the consortium. Alternatively, the consortium chairman may be emailed Richard.inman@paconsulting.com.

TABLE OF CONTENTS

1	Common Element taxonomy	4
1.1	Introduction	4
1.2	Summary view	5
2	Entity reference guide	6
2.1	Definitions	6
2.2	Documentation	6
3	IndividualType	8
3.1	Individual/EmailAddresses	8
3.2	Individual/CountryDomicile	10
3.3	Individual/JobRole	10
3.4	Individual/Division	11
3.5	Individual/DirectTelephoneNumbers	11
3.6	Individual/DirectTelephoneNumbers/Telephone	11
3.7	Individual/Name	12
3.8	Individual/IdentifyingIDs	12
3.9	Individual/ClientCompany	14
4	EmailAddressType	15
5	TelephoneNumberType	16
5.1	TelephoneNumberType/Number	16
5.2	TelephoneNumberType/Kind	16
6	IndividualNameType	18
6.1	IndividualNameType/FamilyName	18
6.2	IndividualNameType/MiddleName	19
6.3	IndividualNameType/GivenName	19
6.4	IndividualNameType/DisplayName	19
7	CompanyContactDetailsType	21
7.1	CompanyContactDetailsType/Name	21
7.2	CompanyContactDetailsType/Address1	22
7.3	CompanyContactDetailsType/Address2	22
7.4	CompanyContactDetailsType/Address3	22
7.5	CompanyContactDetailsType/Address4	23
7.6	CompanyContactDetailsType/PostalCode	23
7.7	CompanyContactDetailsType/StateProvince	23
7.8	CompanyContactDetailsType/City	23
7.9	CompanyContactDetailsType/Country	24
8	ContentSought	25

8.1	ContentSought/UserGroups	25
8.2	ContentSought/ClassificationLevel	26
8.3	ContentSought/ClassificationLevel/RequestedClassificationServiceLevel	26
9	ProductPermissionsType	29
9.1	Summary view	29
9.2	Element Details	29

1 COMMON ELEMENT TAXONOMY

1.1 INTRODUCTION

The Research Entitlements Standard (RES) is the global industry standard mechanism for setting research entitlements.

The standard is made up of a number of components, each with supporting document(s) as follows:

Component	Description	Supporting Documentation
Overview	Outline of the history, goals, and components of the standard	<ul style="list-style-type: none"> Overview
User Permissioning	<p>Describes how vendors and brokers set research permissions, at the level of individual subscribers, using business email address as the unique identifier.</p> <p>This includes the ability to permission by type of user and product, and describes the administration of the linkages between the product groups (used to classify research content) and the user groups (used to classify individuals).</p>	<ul style="list-style-type: none"> User Permissioning Taxonomy.doc Sample-request-usergroups-0.6.xml - a computer-generated sample RESEARCH ENTITLEMENT XML request file showing content sought expressed using user groups Sample-request-rixml-0.6.xml - a computer-generated sample RESEARCH ENTITLEMENT XML request file showing content sought expressed using RIXML Product Classifications Sample-permissioninstructions-0.6.xml - a computer-generated sample RESEARCH ENTITLEMENT XML reply file RIXMLProductClassification.xsd - a sample schema demonstrating use of RIXML ProductClassifications to specify product level grouping Common Elements Taxonomy.doc
Reports	Describes the reports vendors provide to brokers.	<ul style="list-style-type: none"> Reports Taxonomy.doc Sample-pendingreport-0.6.xml - a computer-generated sample RESEARCH ENTITLEMENT XML pending request report file Sample-entitlementreport-0.6.xml - a computer-generated sample RESEARCH ENTITLEMENT XML entitlement report file Sample-pugroup-report-0.6.xml - a computer-generated sample RESEARCH ENTITLEMENT XML product/user group report file Common Elements Taxonomy.doc
Transport	A common technology	<ul style="list-style-type: none"> RESEARCH ENTITLEMENT XML-

Component	Description	Supporting Documentation
Technology	between vendors and brokers to handle all the key permissioning use cases.	0.6.xsd - the core RESEARCH ENTITLEMENT XML Schema

Table 1: Components of the Standard

1.2 SUMMARY VIEW

Some elements in the Research Entitlements Standard XML Schema are used in more than one place. For brevity and clarity, these elements are described separately in this document. The common elements are as follows:

Entity	Definition
IndividualType	Section 3
EmailAddressType	Section 4
TelephoneNumberType	Section 5
IndividualNameType	Section 6
CompanyContactDetailsType	Section 7
ContentSoughtType	Section 8
ProductPermissionsType	Section 9

E.g. the Request element (from the User Permissioning Taxonomy) is defined as:

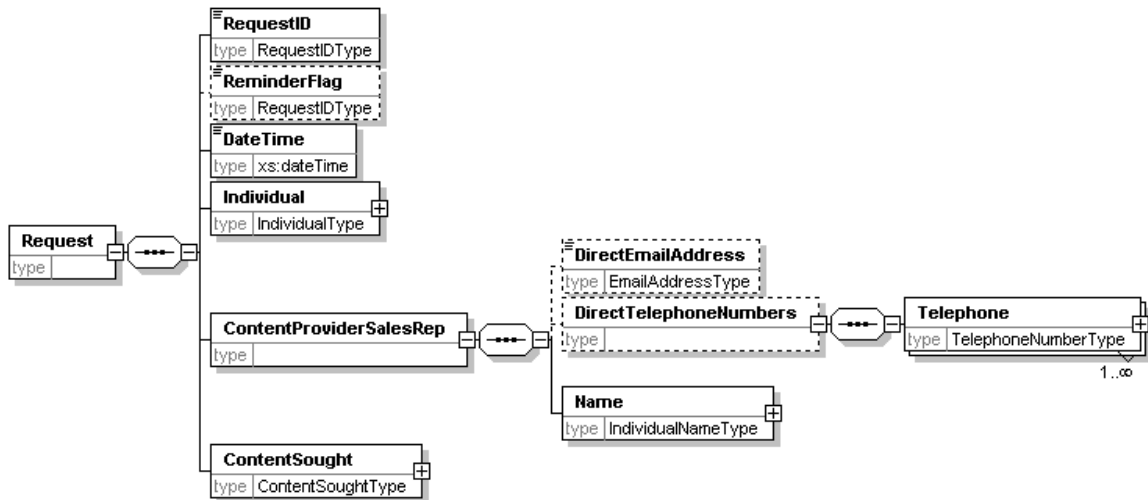

Figure 1: Request entity overview

2 ENTITY REFERENCE GUIDE

2.1 DEFINITIONS

This section lists the definitions of terminology used in this standard.

- **Approver:** the company or person approving the permission request.
- **Attribute:** refers to each data line item within an Entity
- **Client:** the company employing the individual; a consumer of content.
- **Content Creator:** person or company producing the content
- **Entity:** refers to the entire data element, made up of the various Attributes. For example "Entitlement Report"
- **Individual:** the person being permissioned for access to content; a consumer of content
- **Initiator:** the company or person generating the permission request.
- **Report Generator:** the company or person producing the report.
- **Report Reader:** the company or person reading the report.

2.2 DOCUMENTATION

The documents listed on page 5 define the entities of this data set. Information provided for each entity contains the following documentation:

2.2.1 AttributeName

Definition	<i>Definition in italics</i>
Type	Specification allowable data type(s) (See section 2.3.2.)
Required	M = mandatory MA = mandatory if applicable R = Recommended O = optional
Repeatable	Y = yes N = no
Values (Examples)	When data type = "enumerated type," values listed are actual values. When data type = "string," examples are provided.
Notes or Usage Notes	A comments field, including pointers to related documentation. "Usage Notes" provide additional information about examples.
Use	Initiator, Approver

2.2.2 Data types

The following data types are used in this document. All data types should conform to UTF-8 standard (<http://www.utf-8.com/>).

Data Type Definitions	
DateTime	<p>Recorded in compliance with the W3C Note profile, "Representation of dates and times" (http://www.w3.org/TR/NOTE-datetime). The W3C Note defines a profile of ISO 8601, the International Standard for the representation of dates and times.</p> <p>E.g. YYYY-MM-DD HH:MM:SS (with hours 0-24, a space character between the date and time, and a null termination byte)</p> <p>YYYY-MM-DD</p> <p>YYYY-MM</p> <p>YYYY</p>
Enumerated type (restricted to external standard)	A string that may only contain one of a number of values as specified by an existing external standard.
Enumerated type (restricted to list)	<p>A string that may only contain one of a number of values listed.</p> <p>Note: such lists can be implemented and regulated on an institutional basis. This allows for quick adoption of new values when technology, workflow, or nomenclature changes.</p>
Non-negative real	A real number where $r \geq 0$
Positive integer	An integer where $i > 0$
Real	A real number where r may be < 0 .
Reference	A single pointer to another attribute.
String	One or more characters.

3 INDIVIDUALTYPE

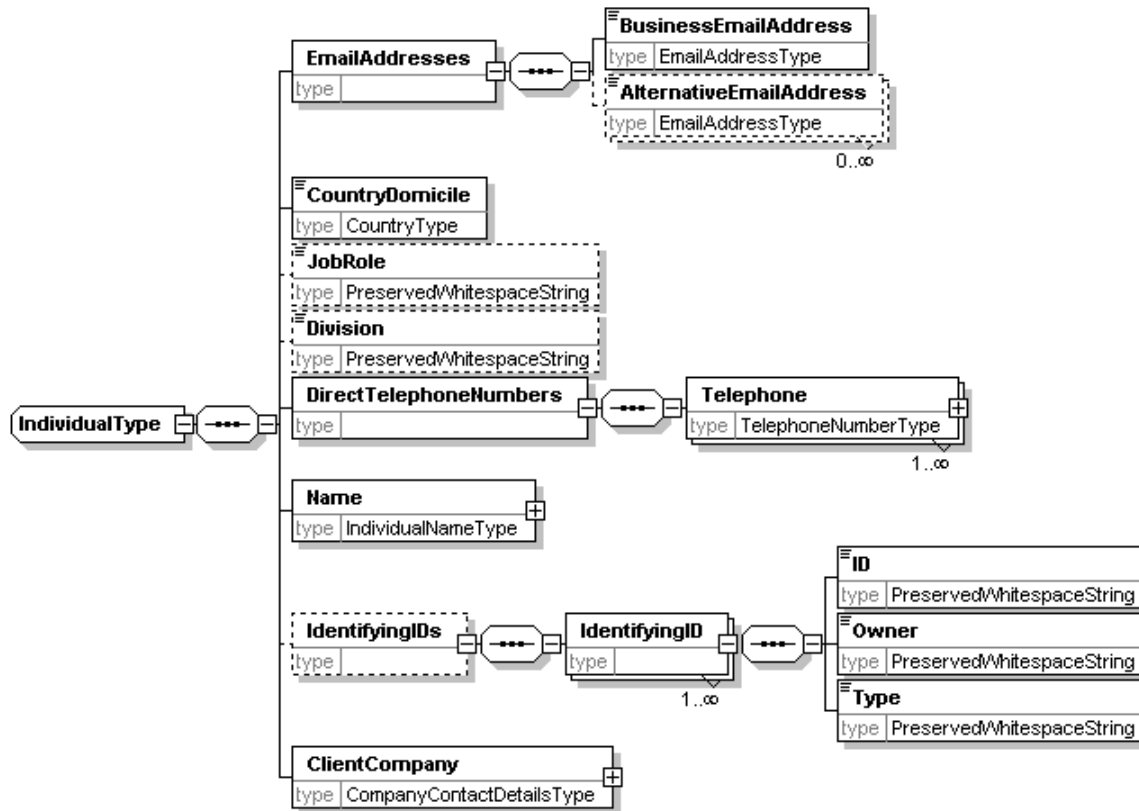

Figure 2: IndividualType element overview

Definition	<i>Containing element enclosing the attributes of an Individual</i>
Type	Container
Required	M
Repeatable	N
Definition	<i>Structural element enclosing the attributes of an Individual's email addresses</i>

3.1 INDIVIDUAL/EMAILADDRESSES

Definition	<i>Containing element enclosing the attributes of a group of email addresses</i>
Type	Container

Required	M
Repeatable	N
Definition	<i>Structural element enclosing the attributes of a group of email addresses</i>
Notes or Usage Notes	An individual's location may affect the content that can be permitted; and this location may differ from the client company's location.

3.1.1 Individual/EmailAddresses/BusinessEmailAddress

Definition	<i>Primary business email address of the individual who is the subject of the request</i>
Type	EmailAddressType Container – See 4
Required	M
Repeatable	N
Values (Examples)	XXXXX@YYYY.ZZZ Baden.Powell@scoutingforboys.co.uk J.R.Hartley@flyfishing.com
Notes or Usage Notes	This is the primary attribute for identifying individuals and matching them against databases such as CRM systems or directories.

3.1.2 Individual/EmailAddresses/AlternativeEmailAddress

Definition	<i>All or any other business email addresses that may be useful in identifying the individual</i>
Type	EmailAddressType – See 4
Required	R
Repeatable	Y
Values (Examples)	XXXXX@YYYY.ZZZ Baden.Powell@scoutingforboys.co.uk J.R.Hartley@flyfishing.com

Notes or Usage Notes	It is common for individuals to have multiple email addresses, particularly when companies change email domain name (e.g. after a merger), or when individuals change their names (e.g. upon marriage in some countries). These should be added where possible, using as many instances of this attribute as necessary, to assist identification of the individual.
-----------------------------	---

3.2 INDIVIDUAL/COUNTRYDOMICILE

Definition	<i>Country in which the individual resides</i>
Type	Enumerated
Required	M
Repeatable	N
Values (Examples)	Enumerated based on the full country names listed in the English section of ISO 3166-1 http://www.iso.org/iso/en/prods-services/iso3166ma/02iso-3166-code-lists/index.html . e.g. Antarctica Central African Republic Paraguay
Notes or Usage Notes	An individual's location may affect the content that can be permitted; and this location may differ from the client company's location.

3.3 INDIVIDUAL/JOBROLE

Definition	<i>Indicates the functional role played by the individual relative to his/her job in the client organisation</i>
Type	PreservedWhiteSpaceString
Required	R
Repeatable	N
Values (Examples)	As agreed between initiators and approvers e.g. Analyst Strategist

	Economist
Notes or Usage Notes	<p>This ensures that approvers are aware when the role supports gaining access to content.</p> <p>The PreservedWhiteSpaceString type retains any whitespace included in the string, e.g. for “Vice President”.</p>

3.4 INDIVIDUAL/DIVISION

Definition	<i>Individual's division or department within the client</i>
Type	PreservedWhiteSpaceString (see 3.2)
Required	R
Repeatable	N
Values (Examples)	<p>As agreed between initiators and approvers</p> <p>e.g. Fixed Income Investments</p>
Notes or Usage Notes	<p>Defines the individual in terms of the internal structure of the client, which may affect the research that can be permissioned e.g. strategic planning would not usually be allowed access to certain investment research even though it contains equities staff whose role, if taken in isolation from the department, would appear to fit into a desirable category.</p>

3.5 INDIVIDUAL/DIRECTTELEPHONENUMBERS

Definition	<i>Container element grouping the telephone numbers for the individual.</i>
Type	Container
Required	M
Repeatable	N

3.6 INDIVIDUAL/DIRECTTELEPHONENUMBERS/TELEPHONE

Definition	<i>Container element grouping the attributes of a telephone number</i>
-------------------	--

Type	TelephoneNumberType Container – See 5
Required	M
Repeatable	Y
Notes or Usage Notes	Multiple instances can be used to capture land-line, cell/mobile, etc. The stipulation is that this be used for <i>direct voice</i> lines only i.e. no fax lines, switchboard lines, etc.

3.7 INDIVIDUAL/NAME

Definition	<i>Container element containing the name details of the individual</i>
Type	IndividualNameType Container - See 6
Required	M
Repeatable	N
Notes or Usage Notes	Supports identification of the individual by the approver.

3.8 INDIVIDUAL/IDENTIFYINGIDS

Definition	<i>Container element grouping the Report Generator or Report Reader IDs for the individual. This element is optional; its absence indicates that no IdentifyingIDs have been captured for the individual.</i>
Type	Container
Required	O
Repeatable	N

3.8.1 Individual/IdentifyingIDs/IdentifyingID

Definition	<i>Container element grouping the Report Generator or Report Reader ID attributes for the individual</i>
Type	Container
Required	M

Repeatable	Y
Notes or Usage Notes	May include IDs identifying individuals or clients. This allows initiators and approvers to agree on provision of IDs where appropriate. Multiple instances of this element can be used to capture multiple IDs.

3.8.2 Individual/IdentifyingIDs/IdentifyingID/ID

Definition	<i>Initiator or Approver ID to assist in identifying the individual</i>
Type	PreservedWhiteSpaceString (see 3.2)
Required	M
Repeatable	N
Values (Examples)	String will vary, depending on the relevant institutional standards. e.g. FS1123Jones
Notes or Usage Notes	May include IDs identifying individuals or clients. This allows initiators and approvers to agree on provision of IDs where appropriate..

3.8.3 Individual/IdentifyingIDs/IdentifyingID/Owner

Definition	<i>Identifies the source (owner) of the IdentifyingID</i>
Type	PreservedWhiteSpaceString (see 3.2)
Required	M
Repeatable	N
Values (Examples)	String will vary, depending on the relevant institutional standards. Examples might include: Factset The Markets.com
Notes or Usage Notes	Mandatory in all IdentifyingID elements. This allows initiators and approvers to agree on provision of IDs where appropriate.

3.8.4 Individual/IdentifyingIDs/IdentifyingID/Type

Definition	<i>Identifies the type or category of IdentifyingID</i>
Type	PreservedWhiteSpaceString (see 3.2)
Required	M
Repeatable	N
Values (Examples)	String will vary, depending on the relevant institutional standards. Examples might include: Bloomberg UUI
Notes or Usage Notes	Mandatory if IdentifyingID is populated. This allows the request to handle cases where more than one type of ID can be usefully employed.

3.9 INDIVIDUAL/CLIENTCOMPANY

Definition	<i>Container element grouping the attributes of the Client company, usually the employer of the individual.</i>
Type	CompanyContactDetailsType Container - See 7.
Required	M
Repeatable	N
Notes or Usage Notes	Supports identification of the individual by the approver.

4 EMAILADDRESSTYPE

Definition	<i>A valid email address</i>
Type	String
Required	M
Repeatable	N
Definition	<i>This element uses a regular expression:</i> <code>"([\,a-zA-Z0-9_-])+@[a-zA-Z0-9_-]+(([\,a-zA-Z0-9_-])*\.[a-zA-Z0-9_-]+)"</code> <i>to validate that the content stored is a valid email address.</i>

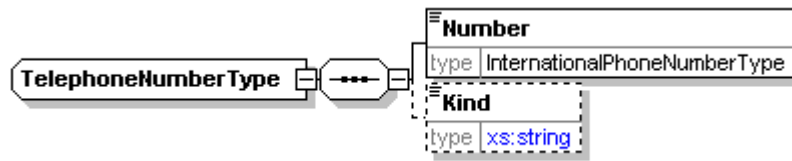

Figure 3: TelephoneNumberType element overview

Definition	<i>Container element grouping the attributes of a telephone number</i>
Type	Container
Required	M
Repeatable	Y
Notes or Usage Notes	Multiple instances can be used to capture land-line, cell/mobile, etc. The stipulation is that this be used for <i>direct voice</i> lines only i.e. no fax lines, switchboard lines, etc.

5.1 TELEPHONENUMBERTYPE/NUMBER

Definition	<i>Direct-dial voice telephone number digits</i>
Type	InternationalPhoneNumberType
Required	M
Repeatable	N
Notes or Usage Notes	<p>Full international telephone number in +CountryCode AreaCode Number format, e.g.</p> <p>+44 1225 323923</p> <p>InternationalPhoneNumberType is a string type which validates content using the following regular expression:</p> <p>"(\+[1-9][0-9]{0,2})([1-9][0-9]{0,4})?([1-9][0-9]{0,13})([0-9]+)?"</p>

5.2 TELEPHONENUMBERTYPE/KIND

Definition	<i>Type of direct-dial voice telephone number</i>
-------------------	---

Type	Enumerated
Required	O
Repeatable	N
Values	"Home", "Mobile/Cell" or "Office"

6 INDIVIDUALNAMETYPE

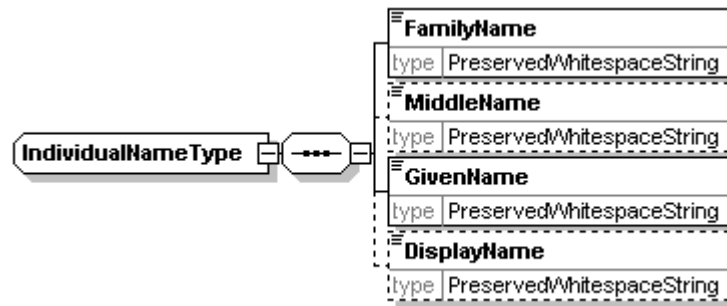

Figure 4: IndividualNameType element overview

Definition	<i>Container element containing the name details of the individual</i>
Type	Container
Required	M
Repeatable	N
Notes or Usage Notes	Supports identification of the individual by the approver.

6.1 INDIVIDUALNAMETYPE/FAMILYNAME

Definition	<i>Family name or surname of the individual</i>
Type	PreservedWhiteSpaceString (see 3.2)
Required	M
Repeatable	N
Values (Examples)	Jones McSweeny Ng Stilton-Cheesewright
Notes or Usage Notes	Supports identification of the individual by the approver.

6.2 INDIVIDUALNAMETYPE/MIDDLENAME

Definition	<i>Middle name or initial of the individual</i>
Type	PreservedWhiteSpaceString (see 3.2)
Required	O
Repeatable	Y
Values (Examples)	J. Florence Dougal
Notes or Usage Notes	Can be used multiple times to capture more than one initial or middle-name. Supports the identification of an individual by the approver.

6.3 INDIVIDUALNAMETYPE/GIVENNAME

Definition	<i>Given or first name of the individual</i>
Type	PreservedWhiteSpaceString (see 3.2)
Required	M
Repeatable	N
Values (Examples)	Bertram William
Notes or Usage Notes	Use the individual's full name where known e.g. use "William" rather than "Bill"; or "James" rather than "Jim".

6.4 INDIVIDUALNAMETYPE/DISPLAYNAME

Definition	<i>Indicates how the individual wants their name to be presented</i>
Type	PreservedWhiteSpaceString (see 3.2)
Required	R
Repeatable	N
Values	Dr. John Doe Sr. CPA, CFA

(Examples)	Bob Smith Robby Smith Rob Smith Bert Smith
-------------------	---

7 COMPANYCONTACTDETAILSTYPE

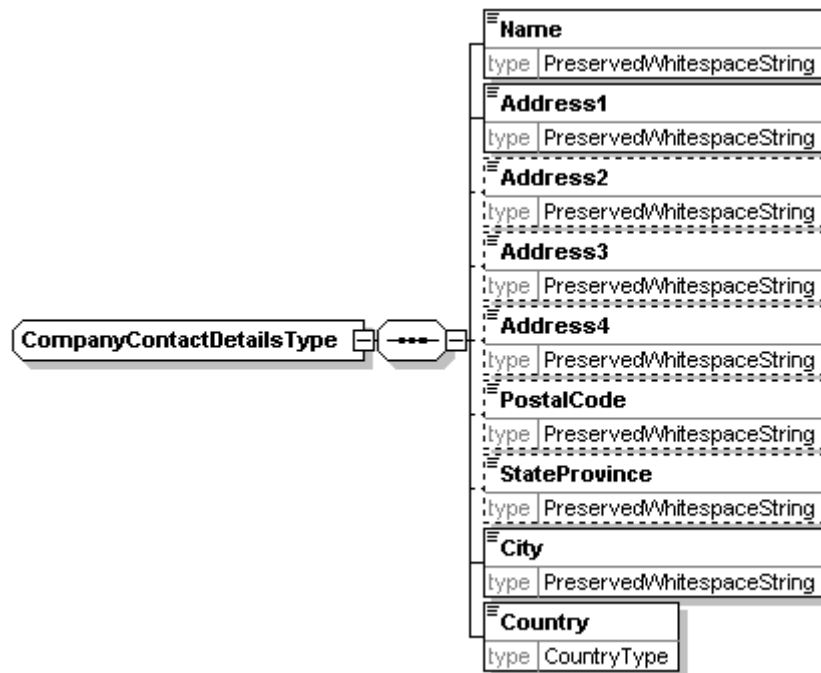

Figure 5: Company contact details type element overview

Definition	<i>Container element grouping the attributes of the Client company, usually the employer of the individual.</i>
Type	Container
Required	M
Repeatable	N

7.1 COMPANYCONTACTDETAILSTYPE/NAME

Definition	<i>Full name of the Client company, usually the employer of the individual.</i>
Type	PreservedWhiteSpaceString (see 3.2)
Required	M
Repeatable	N
Values (Examples)	Use full name of the company where possible, e.g. JPMorgan Securities, Inc.

	PA Consulting Group
Notes or Usage Notes	This is a key item when matching individuals against CRM systems. It is recommended, as most companies are known by more than one variation on their name, that this is enumerated by agreement between institutions.

7.2 COMPANYCONTACTDETAILSTYPE/ADDRESS1

Definition	<i>The first line of the Client company address</i>
Type	PreservedWhiteSpaceString (see 3.2)
Required	M
Repeatable	N
Values (Examples)	Generally street number and name e.g. 123 Buckingham Palace Road Floor 2, The Royal Exchange

7.3 COMPANYCONTACTDETAILSTYPE/ADDRESS2

Definition	<i>The second line of the Client company address</i>
Type	PreservedWhiteSpaceString (see 3.2)
Required	O
Repeatable	N

7.4 COMPANYCONTACTDETAILSTYPE/ADDRESS3

Definition	<i>The third line of the Client company address</i>
Type	PreservedWhiteSpaceString (see 3.2)
Required	O
Repeatable	N

7.5 COMPANYCONTACTDETAILSTYPE/ADDRESS4

Definition	<i>The fourth line of the Client company address</i>
Type	PreservedWhiteSpaceString (see 3.2)
Required	O
Repeatable	N

7.6 COMPANYCONTACTDETAILSTYPE/POSTALCODE

Definition	<i>String that represents the zip/postal code for Client company address</i>
Type	PreservedWhiteSpaceString (see 3.2)
Required	R
Repeatable	N
Values (Examples)	Can be up to 10 characters in length.

7.7 COMPANYCONTACTDETAILSTYPE/STATEPROVINCE

Definition	<i>State or Province in which the Client company is based</i>
Type	PreservedWhiteSpaceString (see 3.2)
Required	R
Repeatable	N
Values (Examples)	Wyoming WA Buckinghamshire

7.8 COMPANYCONTACTDETAILSTYPE/CITY

Definition	<i>City or locality in which the Client company is based</i>
Type	PreservedWhiteSpaceString (see 3.2)

Required	M
Repeatable	N
Values (Examples)	New York London
Notes or Usage Notes	Location of the client company may affect the range of content that can be permissioned. This also supports matching the individual.

7.9 COMPANYCONTACTDETAILSTYPE/COUNTRY

Definition	<i>Country in which the Client company is based</i>
Type	CountryType
Required	M
Repeatable	N
Values (Examples)	<p>CountryType is an enumerated based on the alpha 2 character country codes listed in the English section of ISO 3166-1 http://www.iso.org/iso/en/prods-services/iso3166ma/02iso-3166-code-lists/index.html.</p> <p>e.g. AN GB US</p>
Notes or Usage Notes	Location of the client company may affect the range of content that can be permissioned. This also supports matching the individual.

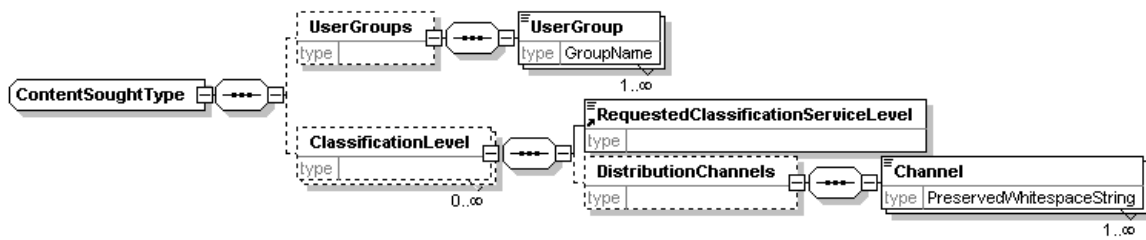

Figure 6: Content sought element overview

Definition	<i>Container element for the desired permissions in terms of the user group(s) and/or service classification levels to which the individual is requesting membership of or access to.</i>
Type	Container
Required	M
Repeatable	N
Notes or Usage Notes	<p>The ContentSought attribute is added to both simplify and introduce flexibility in the way that content sought by a user is described. It specifies the content desired by the requester, which can be expressed in terms of desired user group membership (via a contained UserGroups sub-element) or one or more ClassificationServiceLevel sub-elements (as agreed between broker and vendor).</p> <p>The ContentSought element cannot be empty, i.e. it must contain either a UserGroups element or one or more ClassificationServiceLevel elements (or both).</p>

8.1 CONTENTSOUGHT/USERGROUPS

Definition	<i>This is a container for the desired permissions in terms of the user group(s) to which the individual should be assigned.</i>
Type	Container
Required	O
Repeatable	N

8.1.1 ContentSought/UserGroups/UserGroup

Definition	<i>A user group to which the individual should be assigned.</i>
Type	GroupName String
Required	M
Repeatable	Y
Notes or Usage Notes	A GroupName string is a minimum of one character in length. Group names should not be comprised of white space only to avoid difficulties when matching and combining groups to calculate product access permissions.

8.2 CONTENTSOUGHT/CLASSIFICATIONLEVEL

Definition	<i>Container element for the desired permissions in terms of service classification levels (and distribution channels) to which the individual is requesting access.</i>
Type	Container
Required	O
Repeatable	Y
Notes or Usage Notes	This element replaces the RequestDetail element from the XML schema definition of the initial version of the standard and contains the same RequestedClassificationServiceLevel and DistributionChannels elements. Multiple instances of this attribute can capture multiple classifications or service levels.

8.3 CONTENTSOUGHT/CLASSIFICATIONLEVEL/REQUESTEDCLASSIFICATIONSERVICELEVEL

Definition	<i>This describes the desired permissions in terms of classes of content and service levels</i>
Type	Enumerated
Required	M
Repeatable	N

Values (Examples)	<p>As agreed between institutions e.g. XML tagging of RIXML http://www.rixml.org/ (element ProductClassifications) and GICS http://www.msci.com/equity/gics.html information about investment research.</p> <p>E.g. an individual has access to content classes A, B and C, and the request is to entitle class D and disentitle class C. This attribute (in multiple instances as required) should describe the complete “to be” set of content i.e. A, B, D.</p>
Notes or Usage Notes	<p>Should describe the complete “to-be” set of content. This way, the end-state is unambiguous, despite a single request potentially containing many permission changes.</p> <p>Classes of content: allows for content to be grouped into classes, and permissions allocated against those groups: approvers define granular entitlement by setting up classes of content, each describing a subset of the available content. Individuals are then permissioned against these classes.</p> <p>The Service Level concept allows for some content being made available earlier to some individuals than to others, to support a range of time-based service levels.</p>

8.3.1 ContentSought/ClassificationLevel/DistributionChannels

Definition	<i>Container for zero or more distribution channel elements</i>
Type	Container
Required	O
Repeatable	N

8.3.1.1 CONTENTSOUGHT/CLASSIFICATIONLEVEL/DISTRIBUTIONCHANNELS/CHANNEL

Definition	<i>Identifies the channel through which the content will be distributed.</i>
Type	PreservedWhiteSpaceString (see 3.2)
Required	M
Repeatable	Y
Values (Examples)	<p>As agreed between initiators and approvers</p> <p><i>E.g. ThomsonOne.</i></p>
Notes or Usage	In some cases, content aggregators/vendors have a number of

Notes	distribution channels available. By identifying these in multiple instances of this attribute, then approver is able to permission in the knowledge of where that content will go.
--------------	--

9 PRODUCTPERMISSIONSTYPE

9.1 SUMMARY VIEW

The following figure shows the elements of the ProductPermissionsType entity. Absolute mandatory items are in **bold** outline

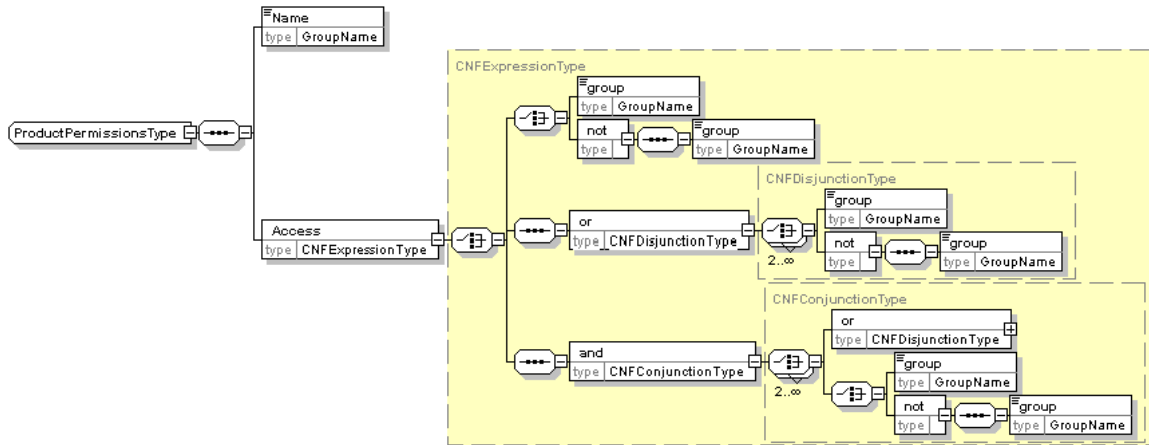

Figure 7: ProductPermissions element overview

9.2 ELEMENT DETAILS

9.2.1 ProductPermissionsType

Definition	<i>This is a container for the desired permissions in terms of the link between a user group and content.</i>
Type	Container
Required	M
Repeatable	N

9.2.2 ProductPermissionsType/Name

Definition	<i>This name of a product group to which a user group is permitted (or denied) access.</i>
Type	String
Required	MA
Repeatable	Y
Notes or Usage Notes	Mandatory where product groups are in use. Each of these <i>Product Groups</i> describing a category such as “Equities” or “European” that

	is meaningful to the broker.
Values (Examples)	“US Equities”

9.2.3 ProductPermissionsType/Access

Definition	<i>This describes the allowable access status of a product group or single document in terms of user group names in a Conjunctive Normal Form (CNF) logical expression. The expression explicitly states which user groups an individual must (or must not) belong to in order to have access to the product group.</i>	
Type	Conjunctive Normal Form logical expression	
Required	M	
Repeatable	N	
Values (Example)	Some examples of CNF permission expressions (in XML syntax):	
	Expression	Meaning
	<group> User Group 1 </group>	Accessible to any individual who is in User Group 1
	<or> <group> User Group 4 </group> <group> User Group 5 </group> <group> User Group 6 </group> </or>	Accessible to any individual who is in User Groups 4, 5 or 6
	<and> <group> User Group 1 </group> <or> <group> User Group 2 </group> <not><group> User Group 3 </group></not> </or> <or> <group> User Group 4 </group> <group> User Group 5 </group> <group> User Group 6 </group> </or> <not><group> User Group 7 </group></not> </and>	Accessible to any individual who is: in (User) Group 1 and either in Group 2 or not in Group 3 and in any one of Groups 4, 5 or 6 and not in Group 7